

STRATEGIC IT DEPLOYMENT IN THE AUTOMOBILE INDUSTRY

David S. Kung, Ph.D.
College of Business and Public Management
University of La Verne

The Supply Chain of An Industry

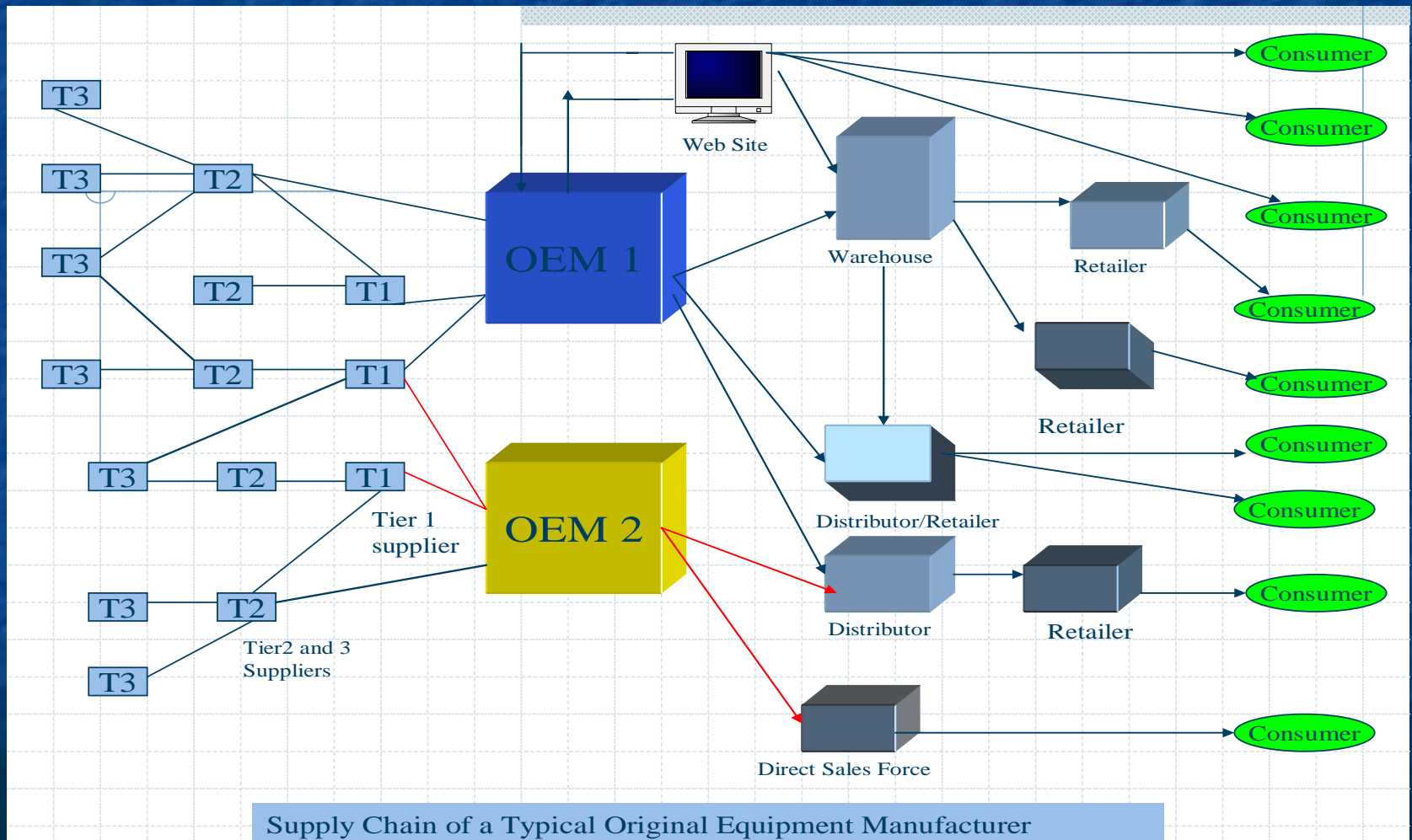

SUPPLY CHAIN LIFE CYCLE STAGES AND ACTIVITIES

- Product-related Activities
 - Product Design
 - Manufacturing
 - Product Life-Cycle Management
- Logistics-related Activities
 - Demand Planning
 - Supply Planning
 - Fulfillment

Supply Chain & Product Characteristics

- Bitability of Product
- Cost Structure
- Information Intensity
- Vertical Supply Chain Collaboration
- Standardization Benefits
- Modularity of Product and Processes

The Automobile Industry

- Supply capacity over demand, globally
- Design, quality, and cost are main drivers
 - Design: satisfying regional characteristics
 - Quality: a standard requirement/perception
 - Cost: Production and Logistics. Availability. Consumer preference.

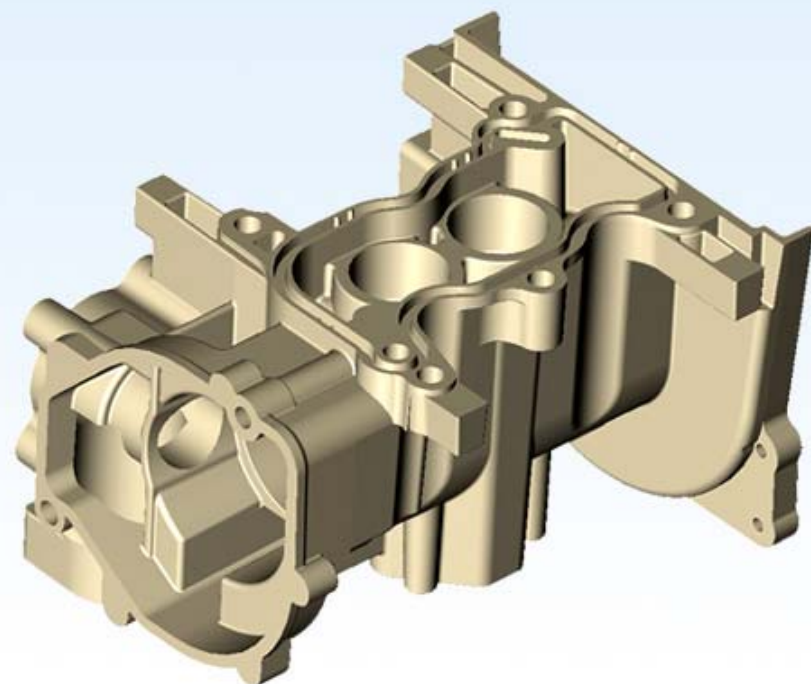
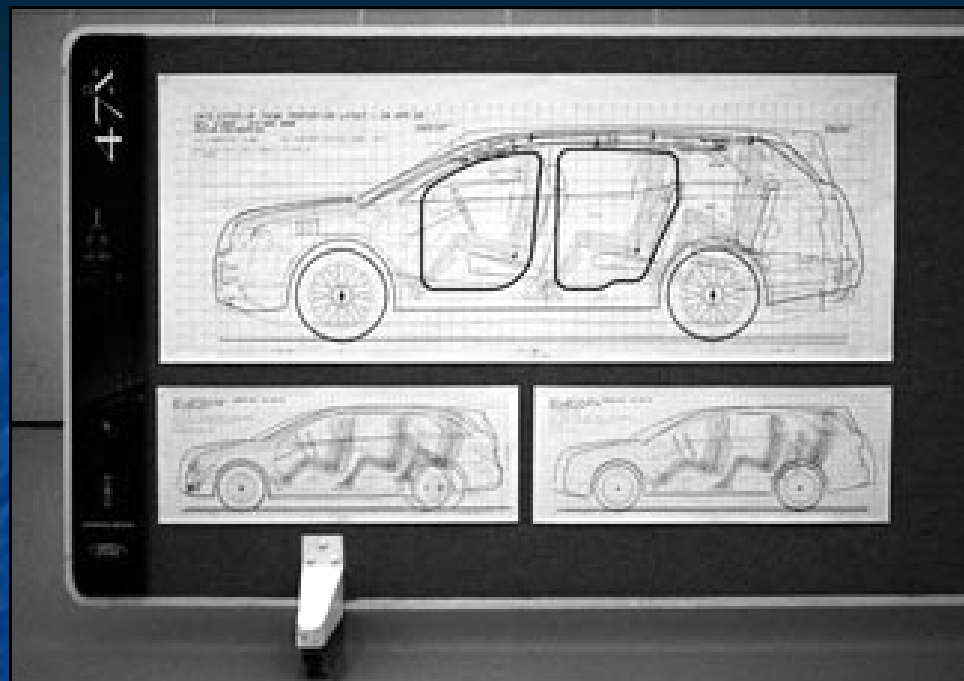

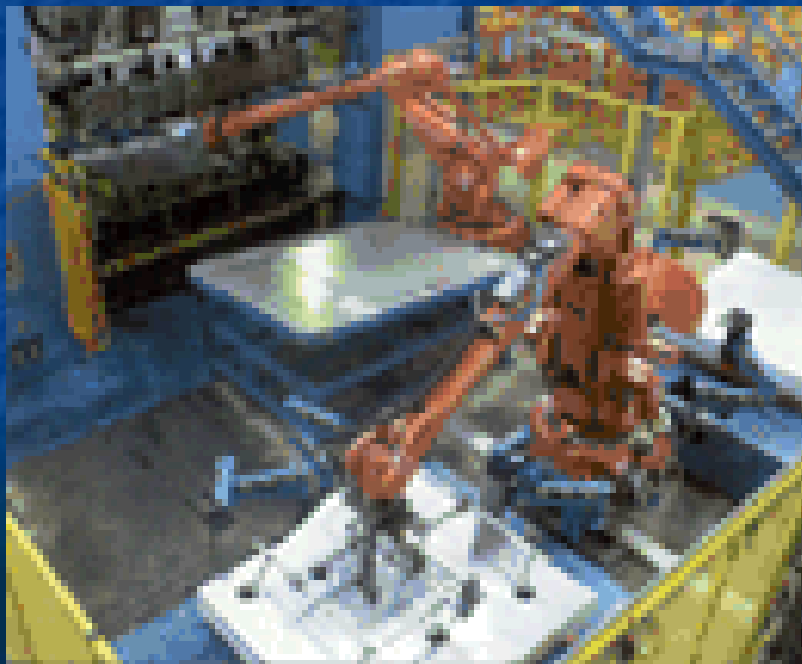

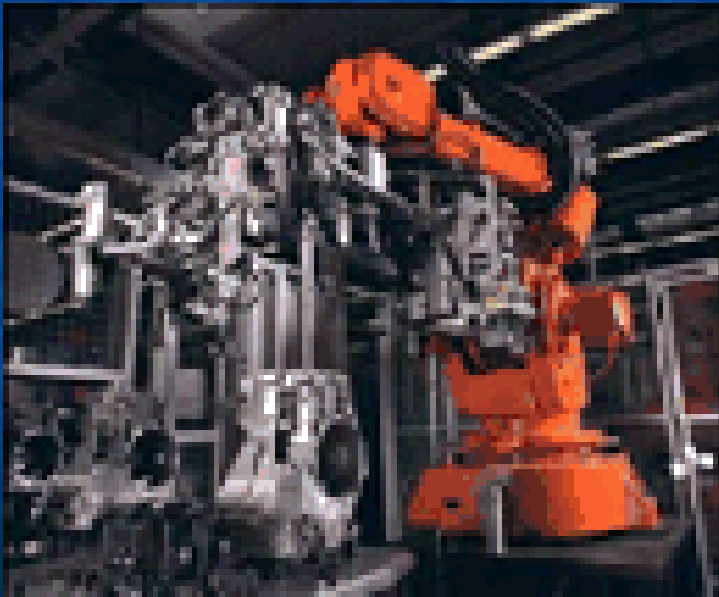

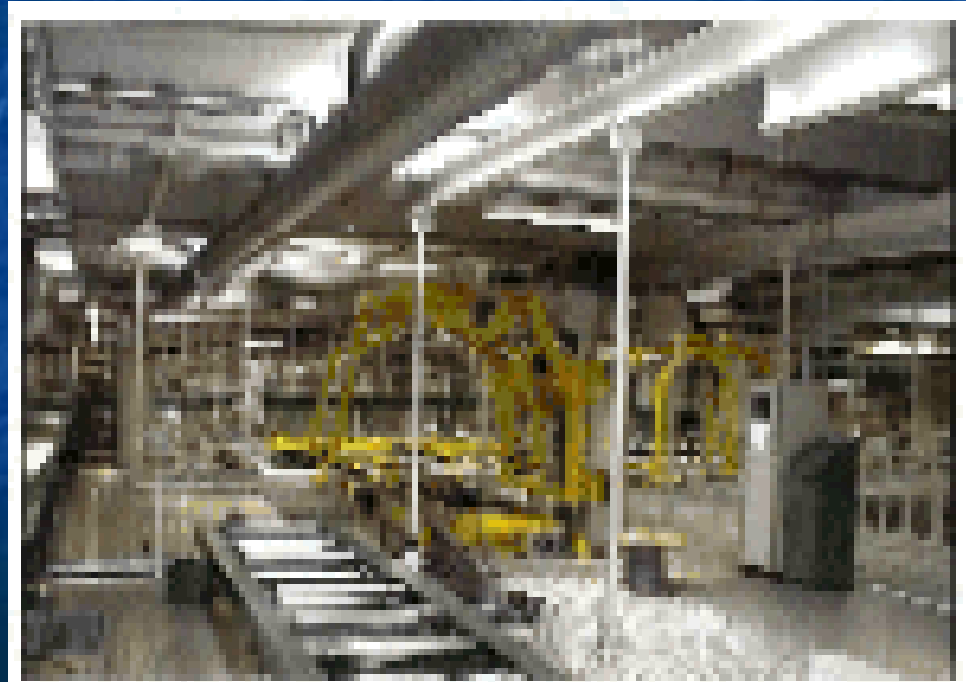
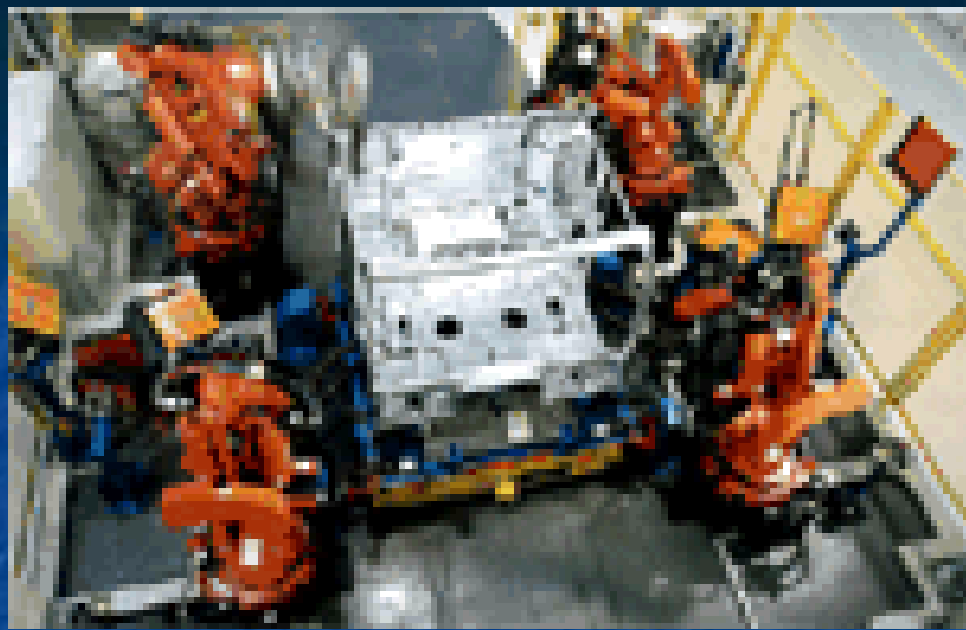

The Automobile Industry		Supply Chain Life-Cycle					
		Product-related			Logistics-related		
		Product Design	Manufacturing	Product Life Cycle Management	Demand Planning	Supply Planning	Fulfillment
Supply Chain & Product Characteristics	Bitability of Product						
	Cost Structure						
	Information Intensity						
	Vertical Supply Chain Collaboration						
	Standardization Benefits						
	Modularity Of Product & Process						

The Automobile Industry SC and Product Characteristics

- Bitability: increasing electronic controls.
- Cost structure: capital intensive.
- Information intensity: very rich.
- Vertical SC collaboration: high opportunity.
- Standardization benefits: structural.
- Modularity: very high. Suitable for postponement strategy.

Strategic Opportunities

- Supply Chain Life Cycle Restructuring.
 - Reduction of Lead time. Increase SC flexibility.
 - Demand-Pull driven.
 - Complete re-structuring of the Product Process.
 - Focus on total supply chain effectiveness, not only manufacturing effectiveness.
- Engagement with consumers.
 - CRM with consumers regarding product information.
 - CRM with consumers in fulfillment process.
 - CRM with consumers in Product Design.