

**The conceptual transformation of IT  
organisations for a short and medium  
term cost reduction through Open  
Source Software**

**Michael Linke**  
EAM Consultancy



## Agenda

---

- Title and Abstract
- Status Quo IT divisional paradigms
- Status Quo Open Source (OS) usage
- Conception of an OS centric IT division
- Conclusion
- Literature
- Q&A



## Title & Abstract

---

- **Title:** The conceptual transformation of IT organisations for a short and medium term cost reduction through Open Source Software
- **Related research topics**
  - IT Governance (ITG)
  - Enterprise Architecture (EA)
  - Software Development (SD)
  - Open Source Software (OSS)

- **Abstract**

*Throughout the last years many organizations worldwide cope with higher demands in delivering faster and flexible business processes to internal and external customers. Additionally since the financial crisis IT budgets are decreasing, but the consumerization of IT still grows constantly. By implementing the Open Source paradigm within the IT department, it may be possible to get access to more feature-rich software faster and cheaper than by the use of COTS (commercial off-the-shelf-software). Although certain measures have to be set up, in terms of working structure and role definitions, in order to establish a sustainable change within IT. Especially the new role of the Technical Business Analyst plays an important role in a Hub & Spoke like relation to internal customers and 3rd party providers.*



## Agenda

---

- Title and Abstract
- Status Quo IT divisional paradigms
- Status Quo Open Source (OS) usage
- Conception of an OS centric IT division
- Conclusion
- Literature
- Q&A

## Status Quo IT divisional paradigms

---

### Organizational structure of IT and embedding in the overall organization diversified over time

- Started with *reporting groups* in the finance domain (reporting to Finance) in the first era of information processing (cp. early usage of IT systems on e.g. OS/360)
- *Centralized IT* organizations, beside Business Units (BU), with specified, integrated IT-related sub-functions (e.g. Quality Assurance)
- *Outtasking / Outsourcing* in various levels of existing IT functions could lead to
- 100% split of *IT Demand & IT Supply*

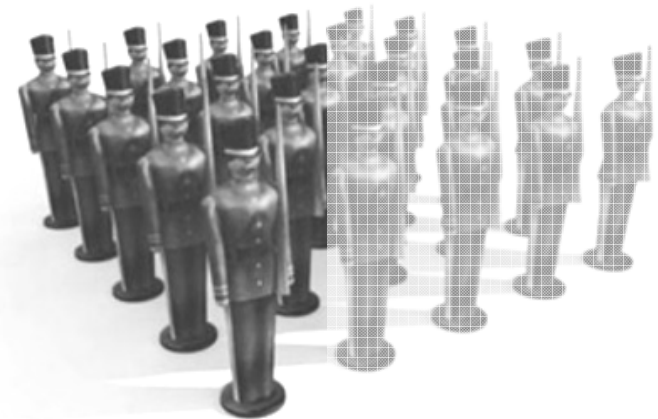

# Status Quo IT divisional paradigms

## Excursus: Enterprise Architecture Model

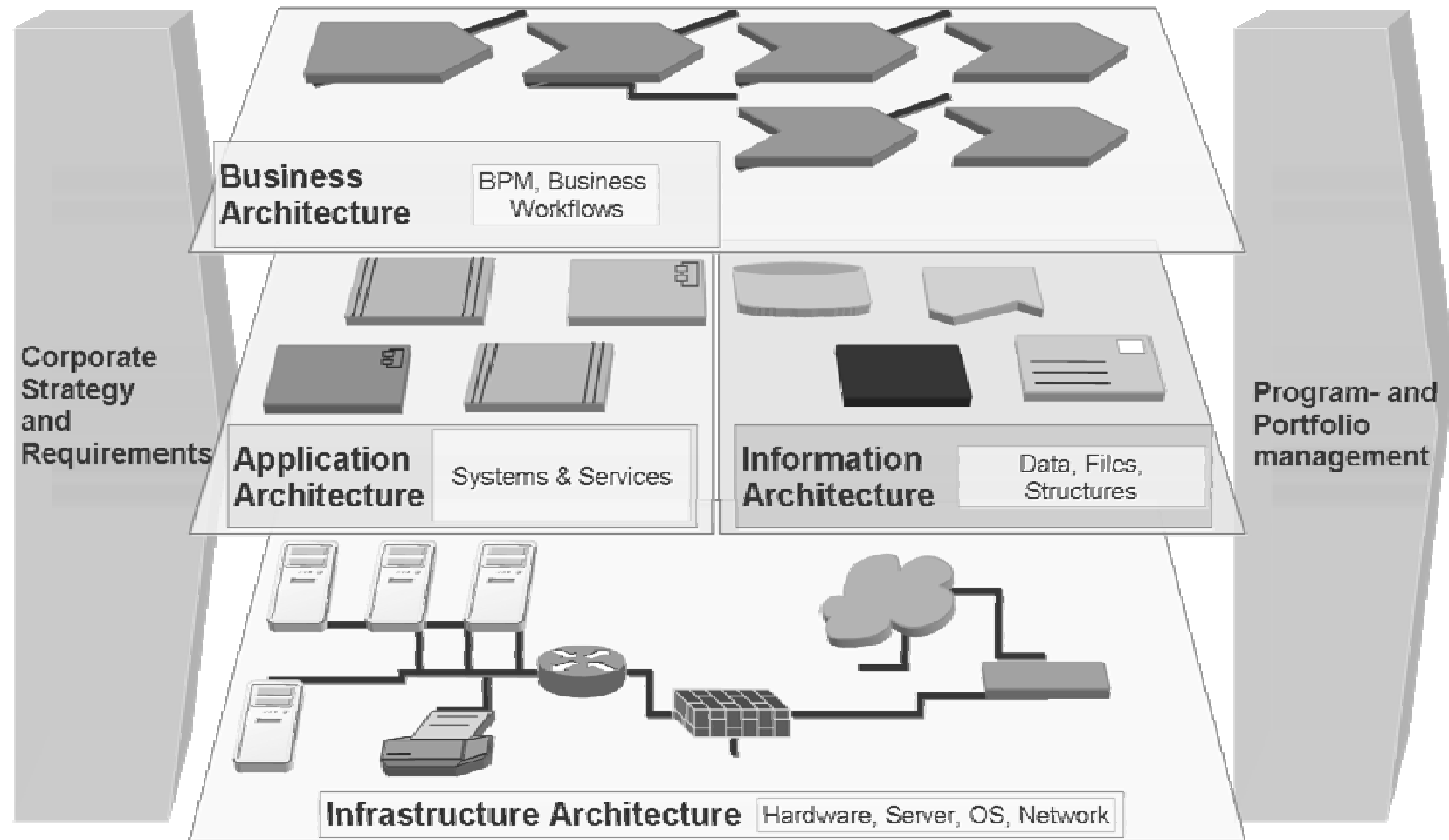

Source.: [IDS01]

# Status Quo IT divisional paradigms

## Excursus: Business Domain Model

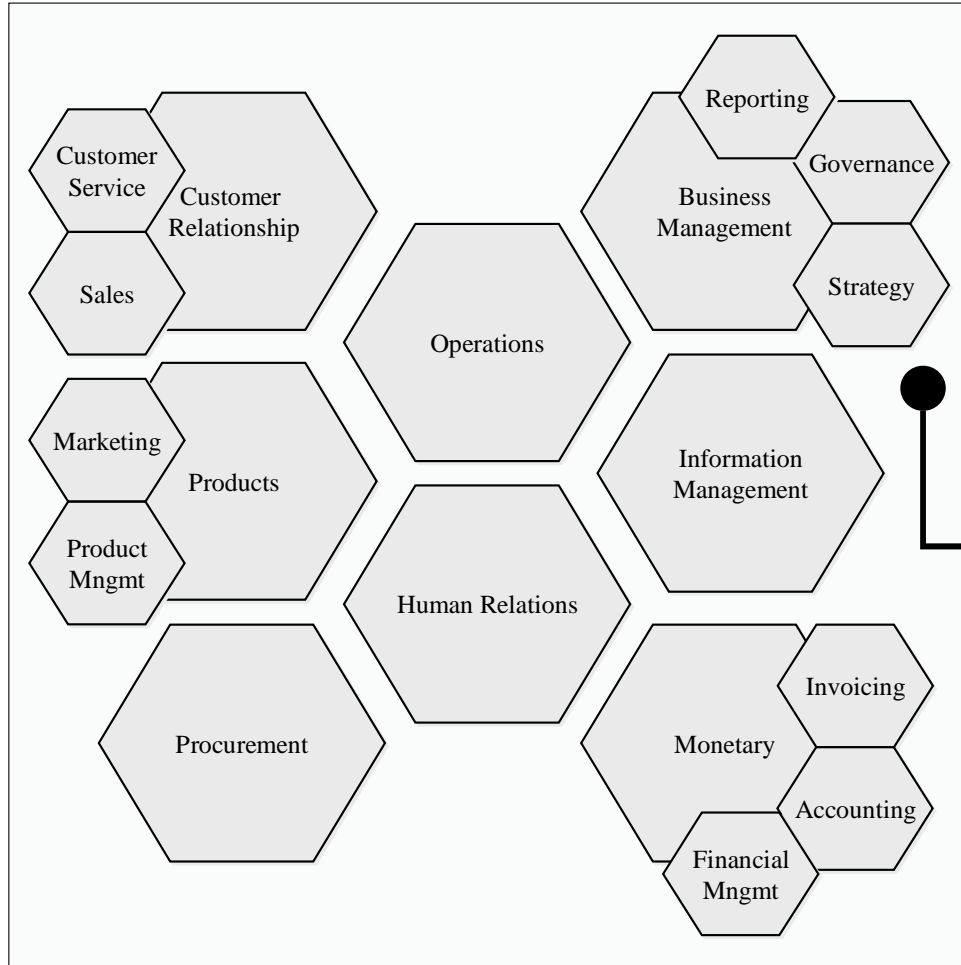

Source.: Own composition

### Characteristics

- Derived from Enterprise Architecture (EA)
- Especially the Business Architecture
- Rough description of business functions
- Could be tailored to organizations specific needs
- No hard borders between the different domains

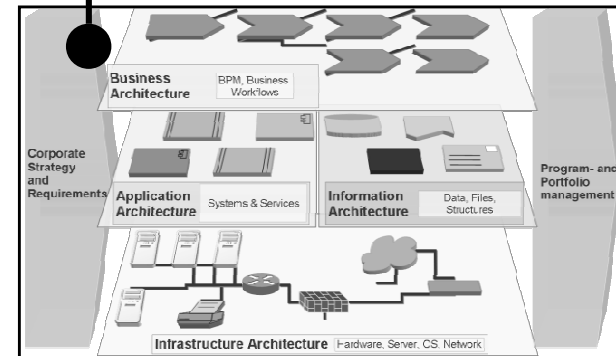

Source.: [IDS01]

# Status Quo IT divisional paradigms

## Examples of IT organisational embedding

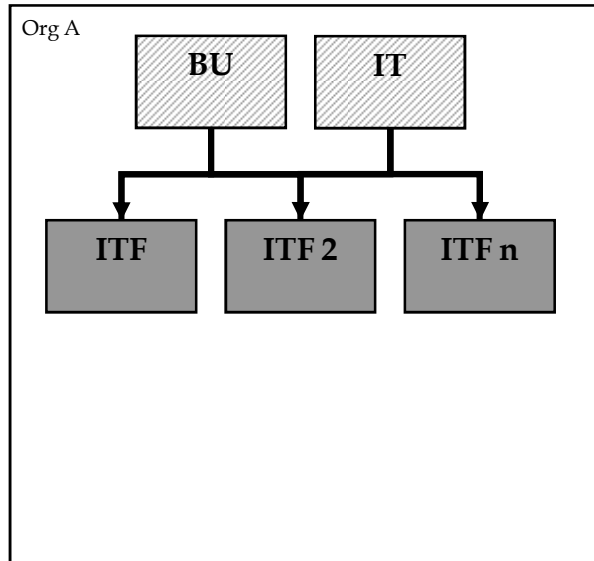

### “Shared responsibility”

- BU and IT led directly the resources
- Shared IT Governance
- Both have CxO functions
- BU and IT engage directly

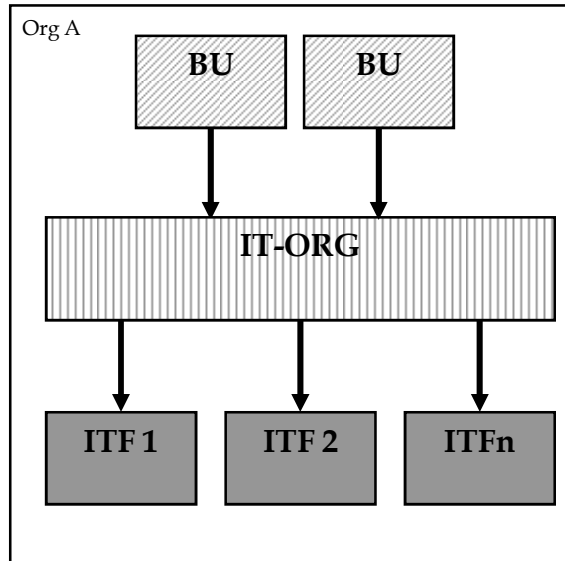

### “IT reports to BU”

- BU steers IT Management organization
- IT Governance on IT side
- No IT CxO function
- Inhouse IT Function

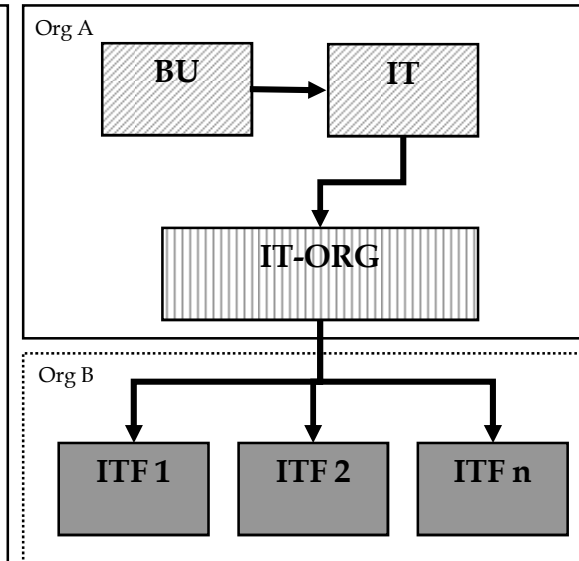

### “Split & Outsourcing”

- BU funnels requirements through IT
- IT Governance on IT side
- IT CxO function
- IT has only inhouse demand staff

Source.: Own composition

Abbreviation: [ITF] IT Function [BU] Business Unit [IT-ORG] IT Organisation



# Status Quo IT divisional paradigms

## Examples of IT organisational embedding II

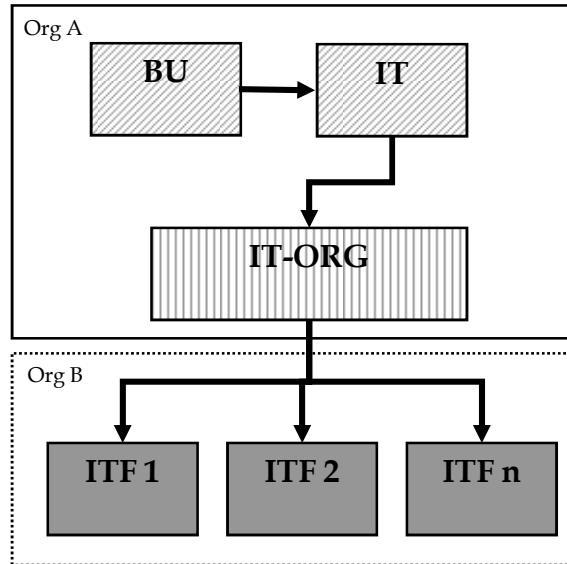

Fig.: Abstract Model

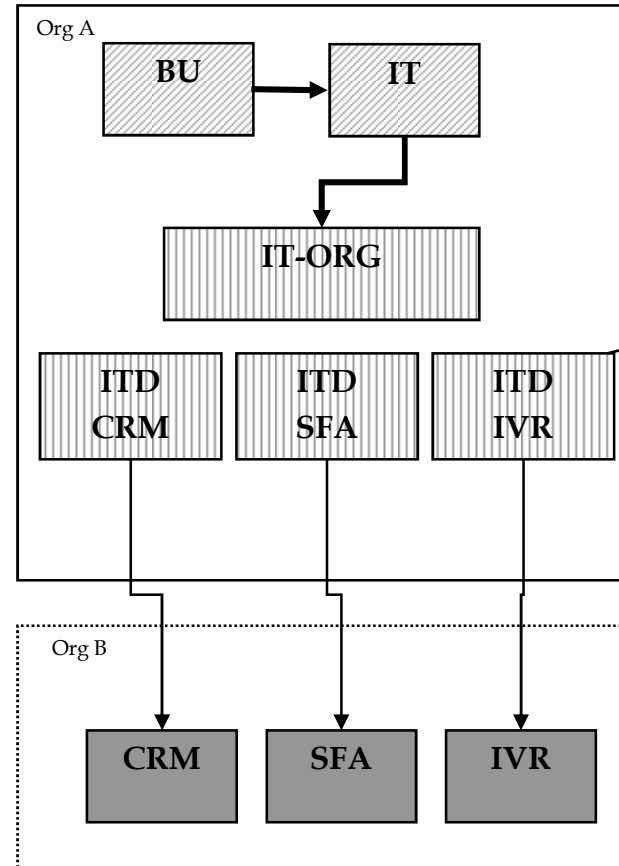
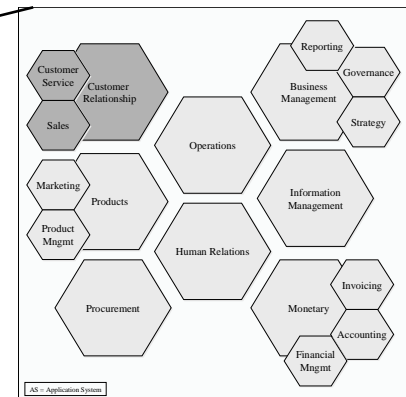

Fig.: Example for Domain "Customer Relationship"



Source.: Own composition

Abbreviation: [ITF] IT Function [BU] Business Unit [IT-ORG] IT Organisation [CRM] Customer relationship Management [SFA] Sales Force Automation [IVR] Interactive Voice Response

# Status Quo IT divisional paradigms

## Elements of IT Demand and Supply Split

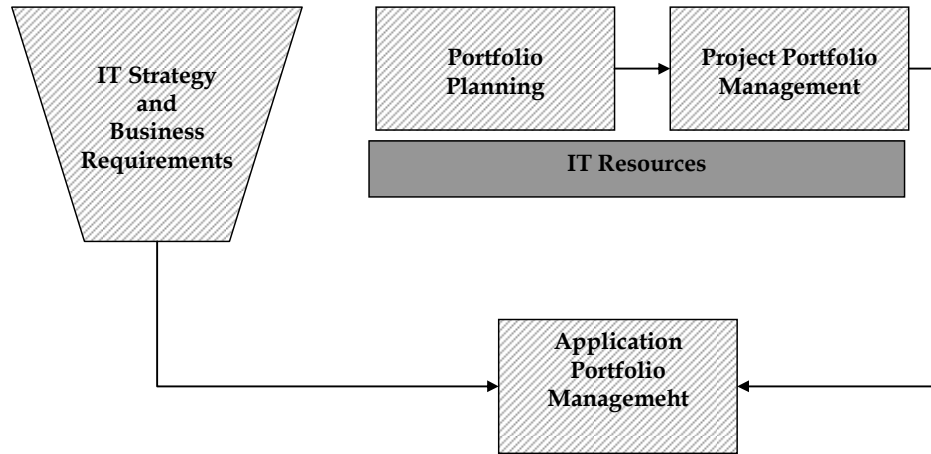

Fig.: From requirements to Portfolio Management (Source: own composition)

### Portfolio Management as a core competence

- Steer and collect business requirements
- Plan and understand business mandates
- Translate into IT system requirements (ISR)
- Feature and application roadmap planning
- Control IT projects and portfolio

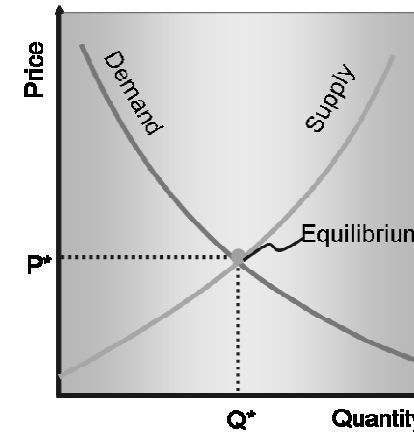

Fig.: Equilibrium of Demand / Supply (Source: [McK06])

### “Law” of Supply and Demand

- IT Demand – requests for IT projects and services generated by business units
- IT Supply – projects and services IT provides the business



## Agenda

---

- Title and Abstract
- Status Quo IT divisional paradigms
- Status Quo Open Source (OS) usage
- Conception of an OS centric IT division
- Conclusion
- Literature
- Q&A

# Status Quo Open Source (OS) usage

## Overview of OS Business

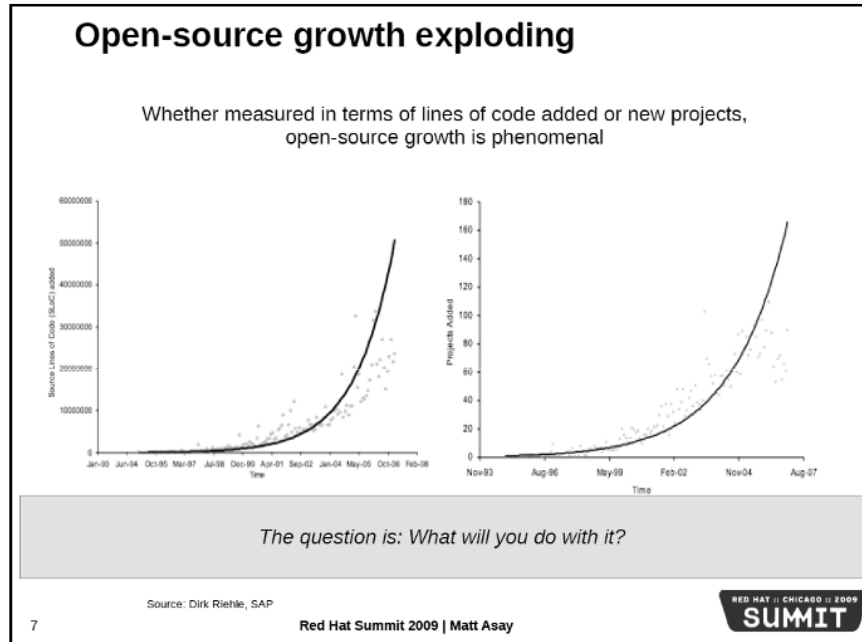

Fig.: Growth of OS codelines (Source: [RedH08])

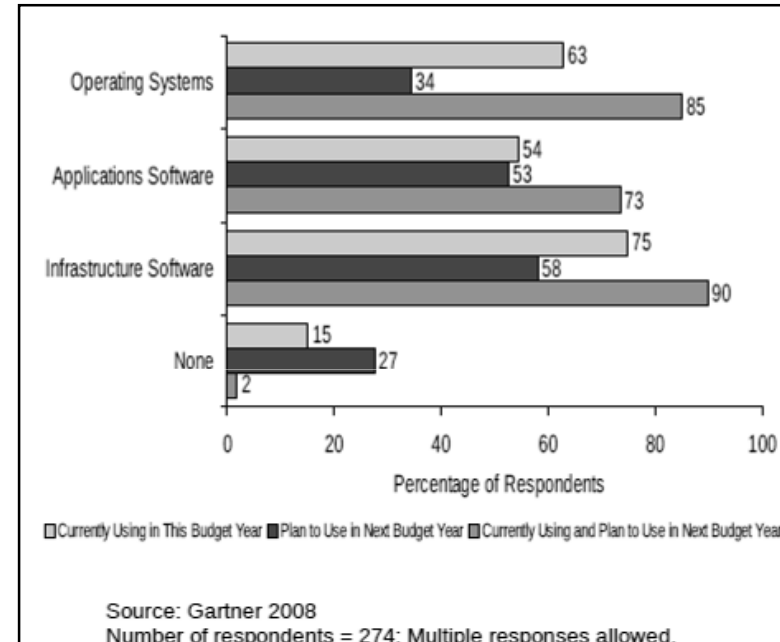

Fig.: Future usage scenarios from corporations (Source: [Gartn08])

### OS Software seems rapidly growing in use and development

- More than 2 million developers on SourceForge in February 2009 [SF09]; over 30,000 for the development of Linux [ BrSt03, p. 619) worldwide.

# Status Quo Open Source (OS) usage

## Open Source Ecosphere and positioning

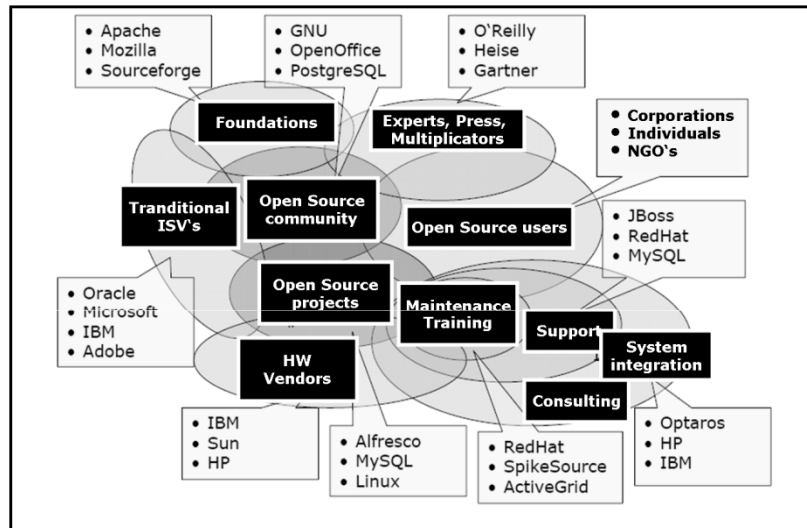

Fig.: Overview Ecosphere (Source: [Opta09])

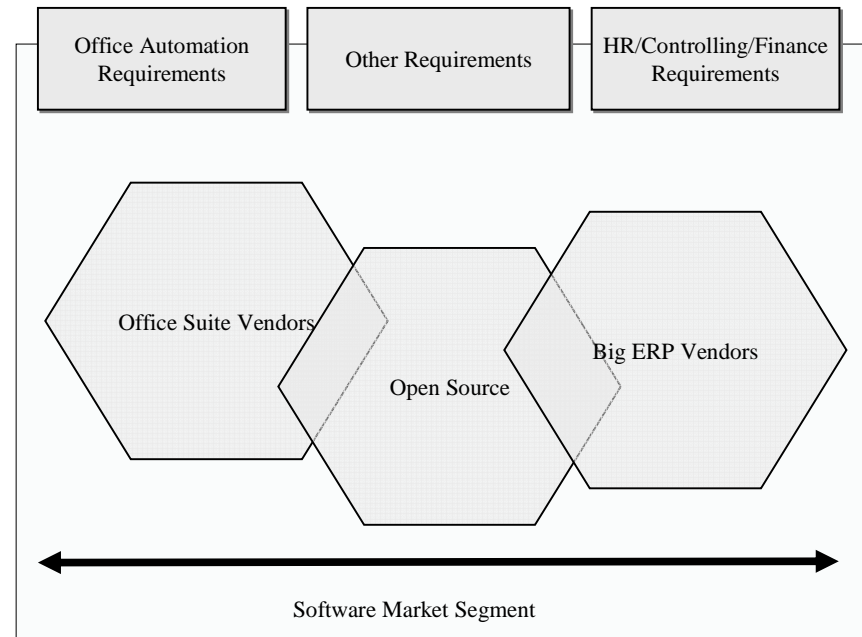

Fig.: Positioning (Source: Own composition based on [Opta09])

# Status Quo Open Source (OS) usage

## Core OS usage idea in the Enterprise: assemble instead of buy

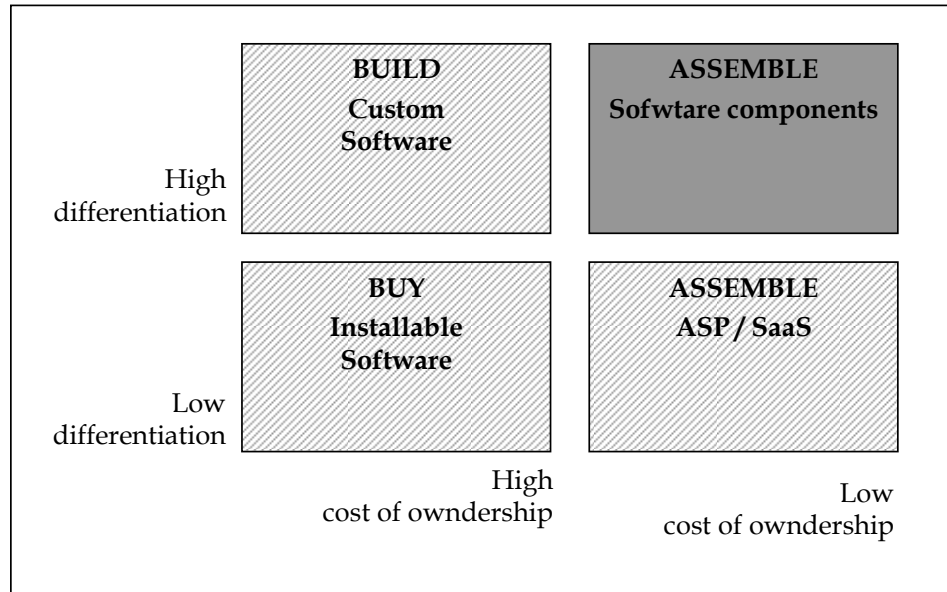

Fig.: Matrix of usage scenarios (Source: [Opta09])

### “Buy Mindset”

- Open Source Software is viewed through the lense of commercial enterprise software
- Lower cost is the primary benefit

### “Assembling Mindset”

- *Differentiation*: Open Source is leading edge of innovation
- *Speed*: 1-2 days to obtain software and begin prototyping versus 3-6 month RFP process
- *Flexibility*: Open Standards eases integration, contribute back to shape roadmap
- *Control*: company, not software vendor determines upgrade timing
- *Standardization*: standard interface not platforms are the key to reduce vendor lock-in

## Status Quo Open Source (OS) usage

---

### Perceived disadvantages of open source models

- There is no guarantee that development will happen.
- There may be significant problems connected to intellectual property.
- It is sometimes difficult to know that a project exist, and its current status.

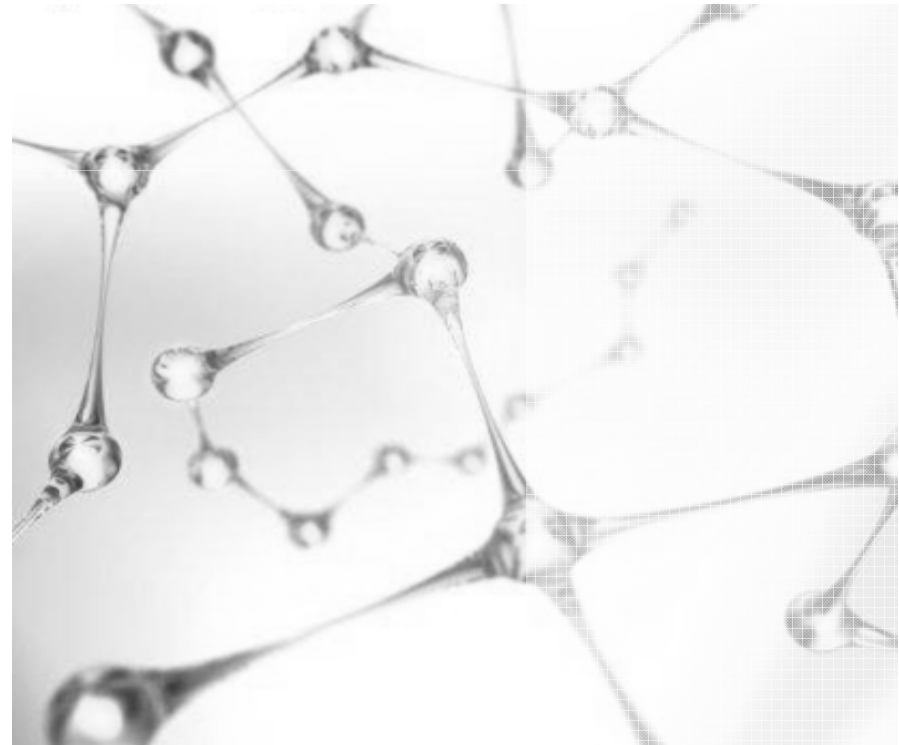
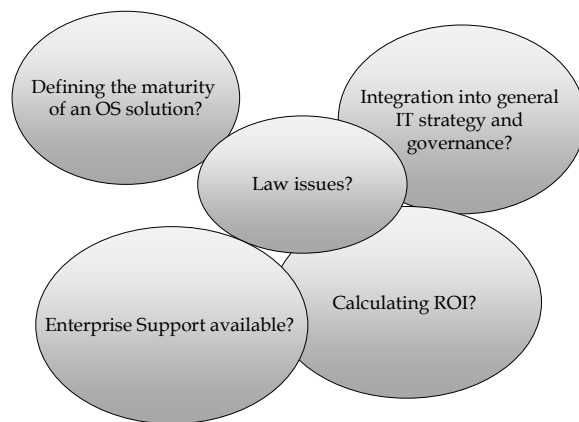



## Agenda

---

- Title and Abstract
- Status Quo IT divisional paradigms
- Status Quo Open Source (OS) usage
- Conception of an OS centric IT division
- Conclusion
- Literature
- Q&A





## Conception of an OS centric IT division

---

### New profile as an enabler in for an IT divisional change

- In the very volatile and fluid OS ecosphere the future development of an OS project appears uncertain regarding the following dimensions:
  - The content or code creation,
  - The roles of the owner, and
  - Concerning the future roadmap.
- Precise knowledge of the established in-house versions, technical assumptions and dependencies (e.g. glibc version, kernel) are therefore of *great importance* for a sustainable, but also medium-term risk reduction. Ideally, this role is held by the *Technical Business Analyst* in a multiplier role as a documenter (e.g. WIKI), as well as a project manager for software assemblies. This role seems not be possible to establish in a pure IT/Demand-Supply organization.
- He is here for a centrally controlled agency, documented in accordance with its classification in the IT organization.[Dint08, p. 149-150].

## Conception of an OS centric IT division

### New role of Technical Business Analyst in a „Hub & Spoke“ Architecture

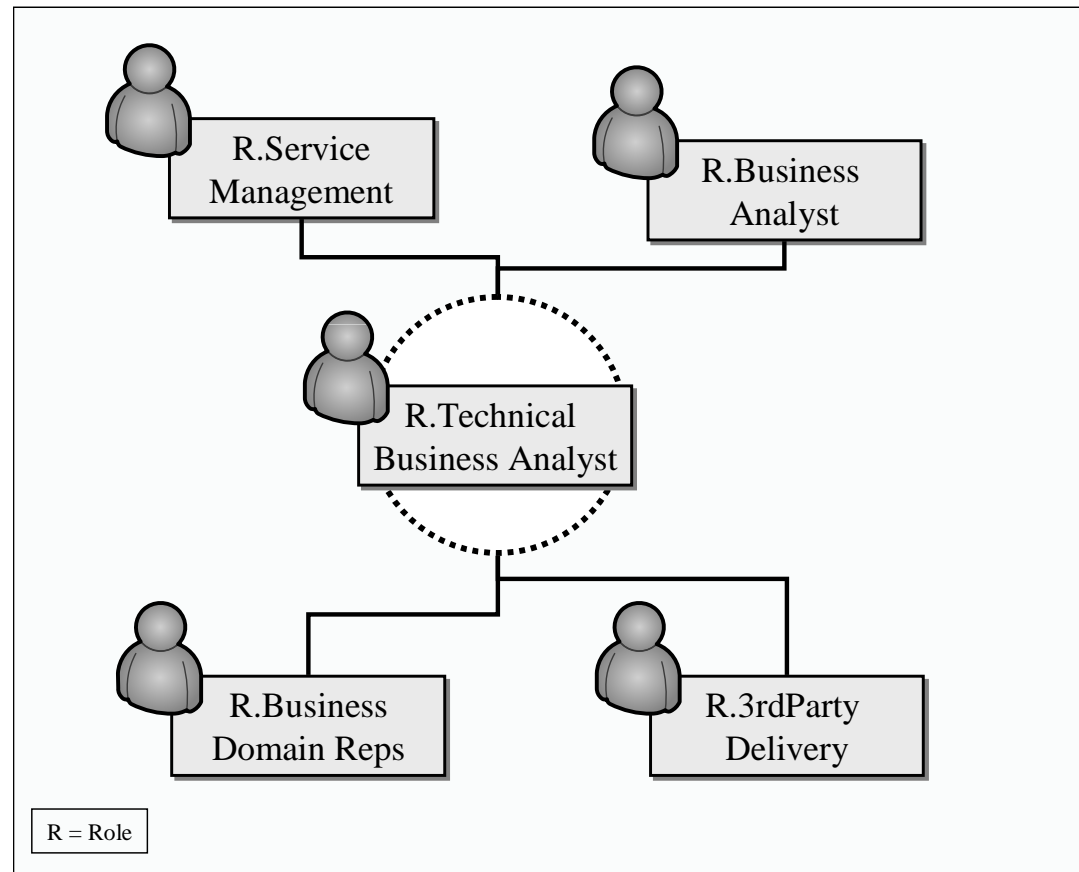

Fig.: Hub & Spoke roles of the Technical Business Analyst (Source: Own composition)

# Conception of an OS centric IT division

## OS centric IR organization

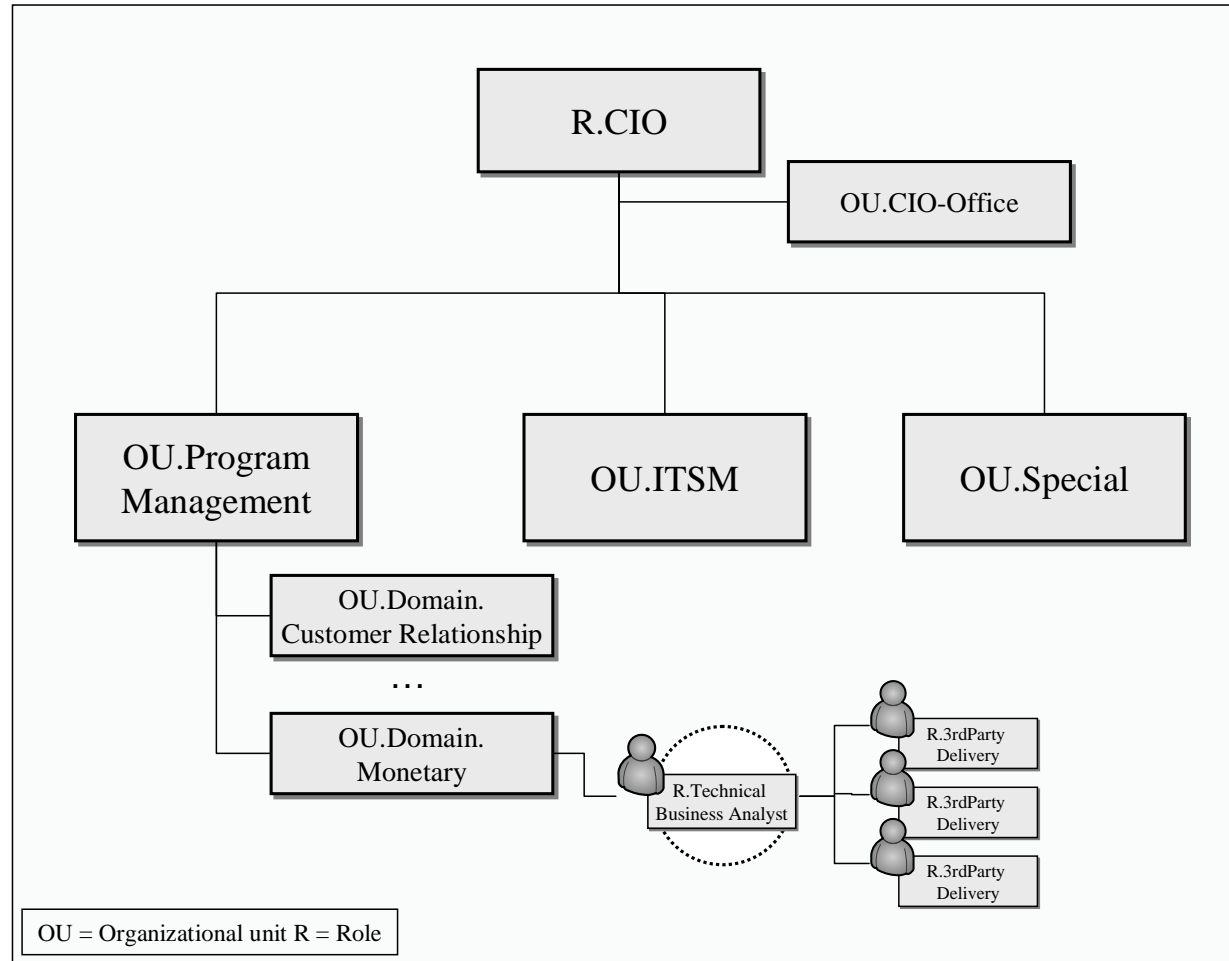

Fig.: Overview of roles and function/subfunctions (Source: Own composition)

# Conception of an OS centric IT division

## Mapping of current (2010) OS solutions and Business Domains

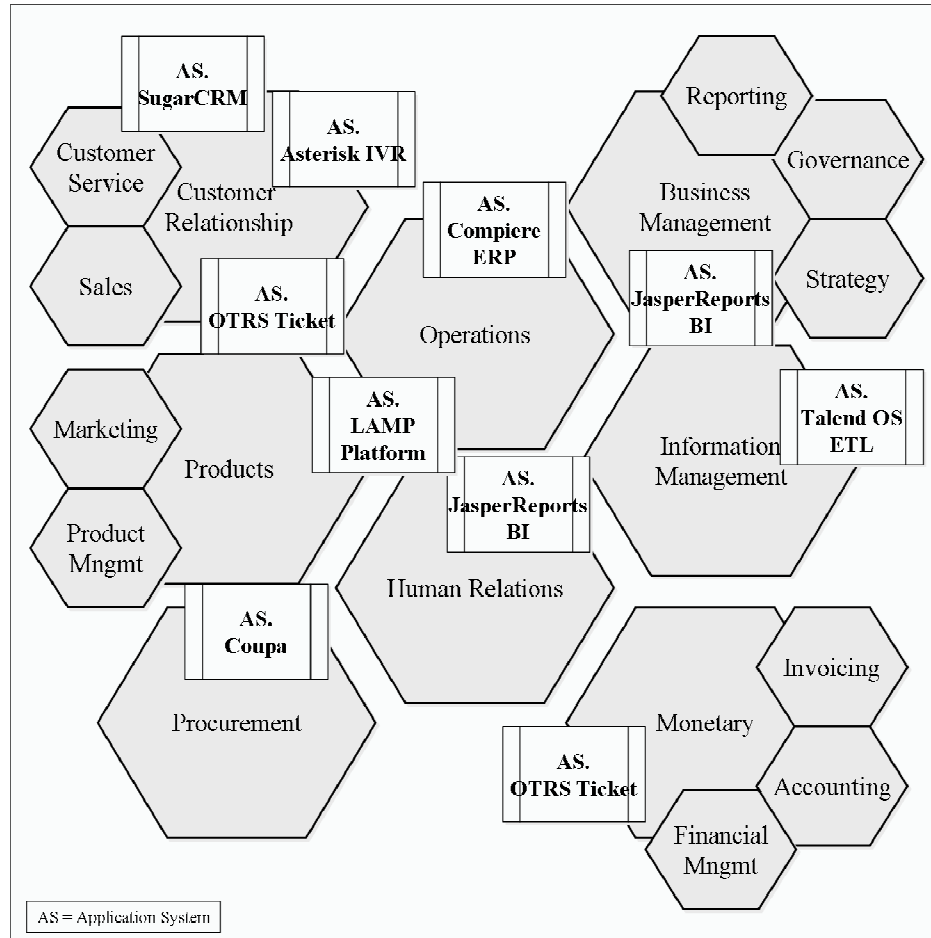

Fig.: Overview of Business Domains and current OS solutions (Source: Own composition)

# Conception of an OS centric IT division

## FTE calculations and staff example in transport logistics

Domain	Role Function	[FTE]	[MO]	Domain	Role Function	[FTE]	[MO]
<b>Marketing/Sales/Web/CRM</b>				<b>Production</b>			
	Head	1	80		Head	1	80
	Team-Member	2	70		Team-Member	0	70
		3	150			1	80
	3rd Party OS Developer*	8	50		3rd Party OS D	9	50
		8	400			6	450
	Sum	./.	550		Sum	./.	530
<b>BI &amp; Reporting</b>				<b>Overall Sum</b>			
	Head	1	80				
	Team-Member	0	70				
		1	80				
	3rd Party OS Developer*	6	50				
		6	300				
	Sum	./.	380				
	* Available person days are dependent from different influencing factors: decreasing factor (DF) - margin of provider - increasing factor (IF) - nearshore/offshore price decrease possibility						
	FTE = Full Time Equivalent						
	MO = Money Unit						

- *Marketing / Sales / Web / CRM: 2-4 FTE Technical Business Analyst serves 3-15 Open Source Developer / Assemblers for CRM and Web-themes (eg SugarCRM, Drupal CMS)*
- *BI & Reporting: 1 FTE Technical Business Analyst serves 3-8 Open Source Developer / Assemblers for Business Intelligence (BI) and reporting issues (eg, Pentaho, Jasper Reports)*
- *Production: 2-3 RTD Technical Business Analyst supervises 3-12 Open Source Developer / Assemblers for Operations issues (eg: Openbravo, OpenERP)*

## Conception of an OS centric IT division



>> Google processes its data on a standard machine cluster node consisting two 2 GHz Intel Xeon processors with Hyper-Threading enabled, 4 GB of memory, two 160 GB IDE hard drives and a gigabit Ethernet link on Linux OS. <<

MapReduce statistics for different months

	Aug. 2004	Mar. 2006	Sep. 2007
Number of jobs (1000s)	29	171	2,217
Avg. completion time (secs)	634	874	395
Machine years used	217	2,002	11,081
map input data (TB)	3,288	52,254	403,152
map output data (TB)	758	6,743	34,774
reduce output data (TB)	193	2,970	14,018
Avg. machines per job	157	268	394
Unique implementations			
map	395	1,958	4,083
reduce	269	1,208	2,418

Fig.: Statistics from Google research regarding the usage of their MapReduce platform (Source: [Goo06])

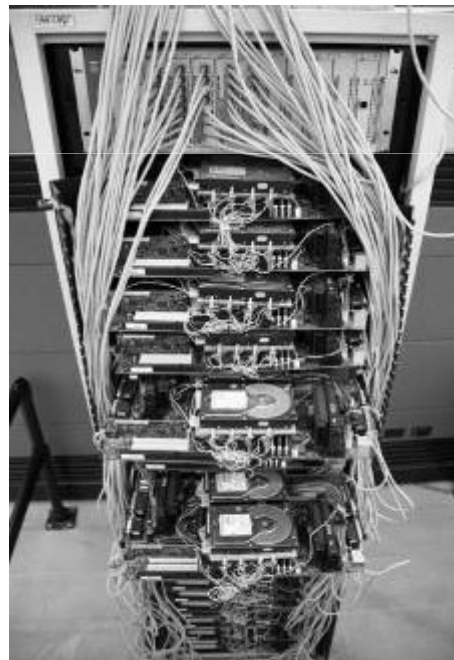

Fig.: 1st Google data center rack (Source: [Goo06])

- No ITSM-software
- No fibre channel
- No SCSI, just IDE
- No IBM, HP, SUN HwW
- 450.000 servers in 2006
- 1x OS
- 1x Filesystem
- 1x DB



## Agenda

---

- Title and Abstract
- Status Quo IT divisional paradigms
- Status Quo Open Source (OS) usage
- Conception of an OS centric IT division
- Conclusion
- Literature
- Q&A



## Conclusion

---

### Summary and Outlook

- In summary, it can be postulated that the pressure on IT organizations to deliver software projects more efficiently has grown more than ever.
- Increasing consumerisation of IT, including further increases in distribution / allocation of the global value chain. Discussions around 20-30% of maintenance costs, especially in the ERP environment, also contribute to an increasing search for alternatives.
- Open Source Software, with an assumed 80/20-Pareto distribution of software features vs. 20/80-shares on licensing costs (compared with COTS), make this branch of software development especially attractive.
- The organisational structure should be adapted accordingly, in particular through the new role of the *Technical Business Analyst* as a central monitoring entity who can control Open Source assemblies. The most important function of this new key role is the participation of the involved software communities, as well as the documentation of individual projects, technologies, release levels, etc. His commitment has to be secured through possible appropriate and legal HR activities, whether through a penalty in an earlier department, but also by an attractive salary.





## Agenda

---

- Title and Abstract
- Status Quo IT divisional paradigms
- Status Quo Open Source (OS) usage
- Conception of an OS centric IT division
- Conclusion
- Literature
- Q&A